

Door panel layout For centre-opening landing doors and car doors

L/C-4-C

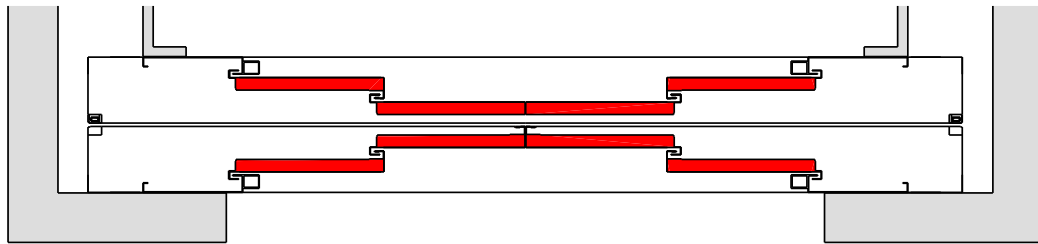

L/C-6-Z

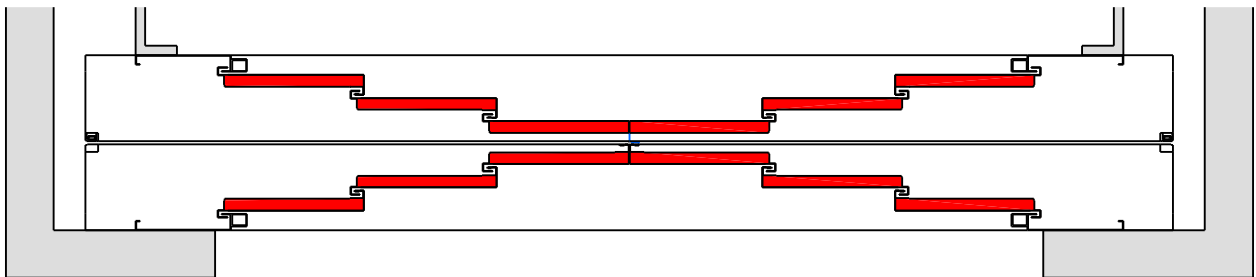

General planning information:

- The door should be set compl. In the shaft (shaft wall installation as shown). Niche installation is not permitted!
- Car door always delivered with Frame and Ram Protection
- 10mm gaps between door panel/door panel respectively door panel/door frame
- Coupling of landing and car door with optical coupling → 10mm sill gap possible
- Electric closing device → emergency unlocking from the pit possible with an additional switch
- Fast open and closing times achievable
- Meiller-USP for landing or car doors:

one UPS for two landing or car doors with single drive

one UPS for one landing or car door with dual drive

- Max. sill load

Door type	Landing door: single standard sill brackets	Landing door: continuous sill support	Sill load (without substructure)
K/S-6-Z	6,5 t wheel load / 13,0 t axis load	9,0 t wheel load / 18,0 t axis load	9,0 t wheel load / 18,0 t axis load
K/S-4-Z	8,5 t wheel load / 17,0 t axis load	9,0 t wheel load / 18,0 t axis load	9,0 t wheel load / 18,0 t axis load

- Because of the large total depth of the landing door, the horizontal lug to the landing wall must be observed according to the norm and may have to be protected by the client.

Shaft wall cut out L-4/6-C

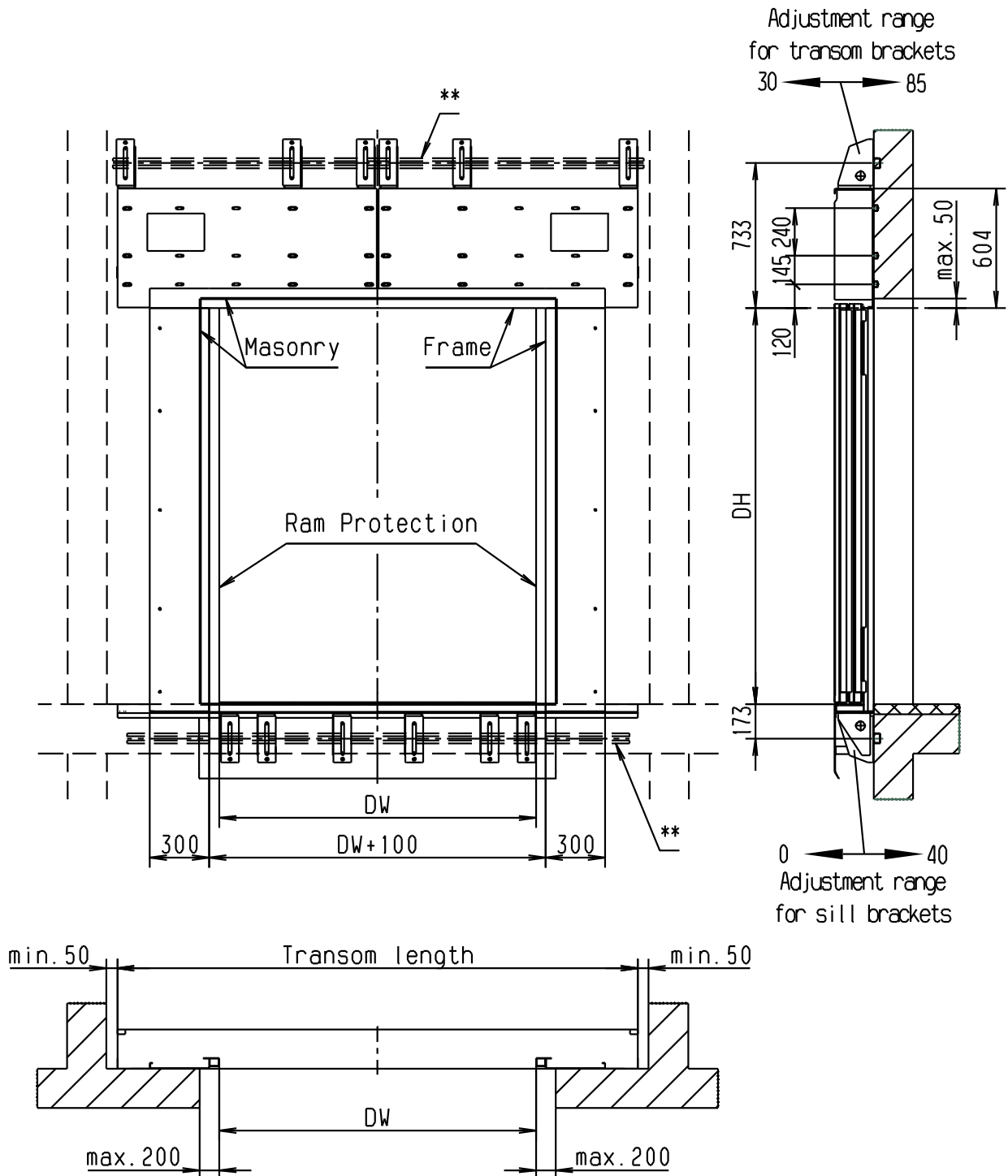

** Anchor rails for max. M16 screws for transom- and sill fastening brackets (not included in scope of delivery)

DW: Door width
DH: Door height

Subject to dimensional changes!

Fixing chart for centre-opening landing doors L-4-C

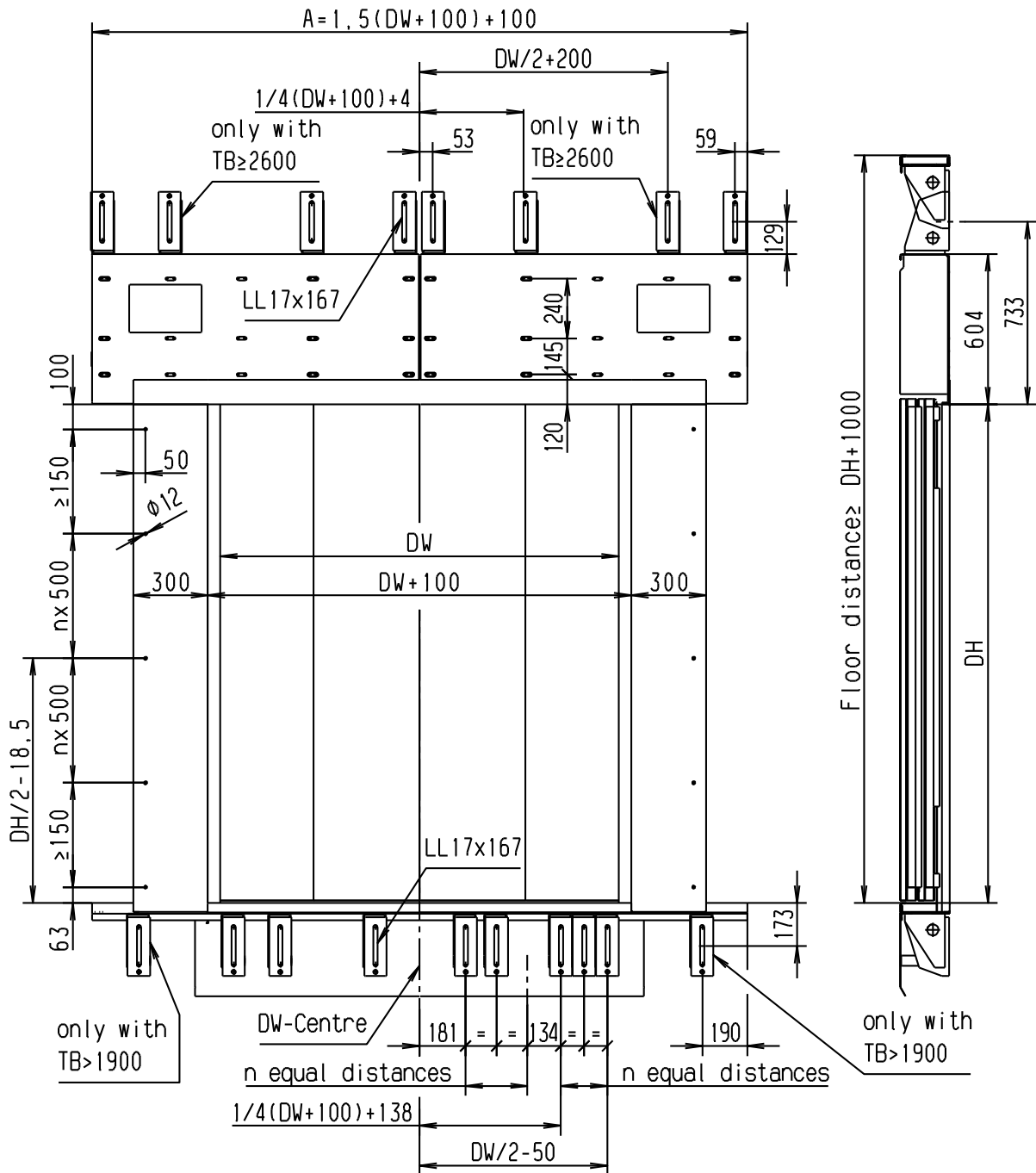

DW: Door width
DH: Door height

Position of transom fixing points L-4-C see figures at page 7-8

Subject to dimensional changes!

Dimensioned sheet L-4-C

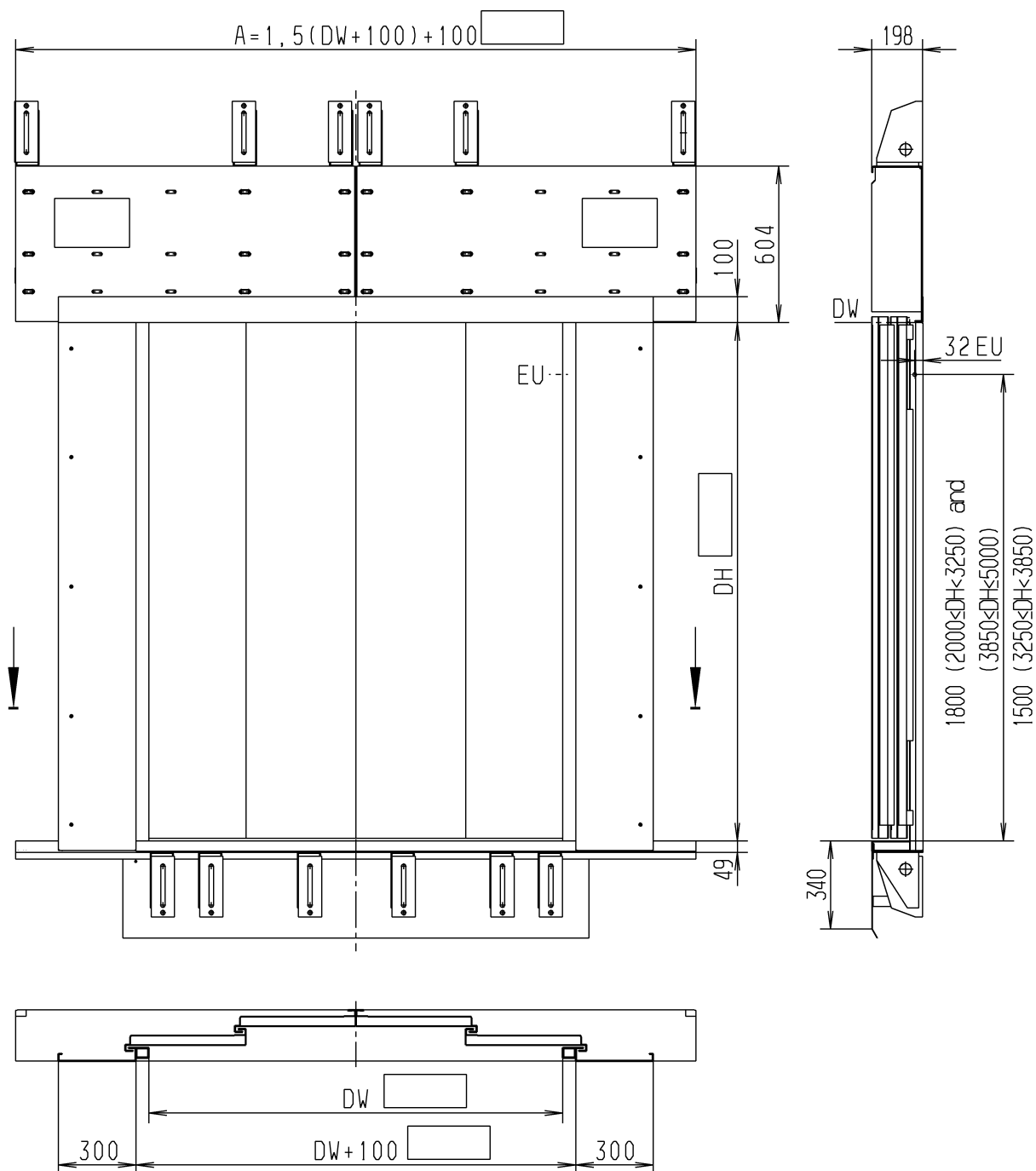

DW: Door width 1600 - 5300mm
DH: Door height 2000 - 5000mm

EU: Emergency unlocking device (EU is fitted by default in the right side frame. It is possible to relocate the EU in the left side frame on site.)

Subject to dimensional changes!

**Fixing chart for centre-opening car doors
C-4-C**

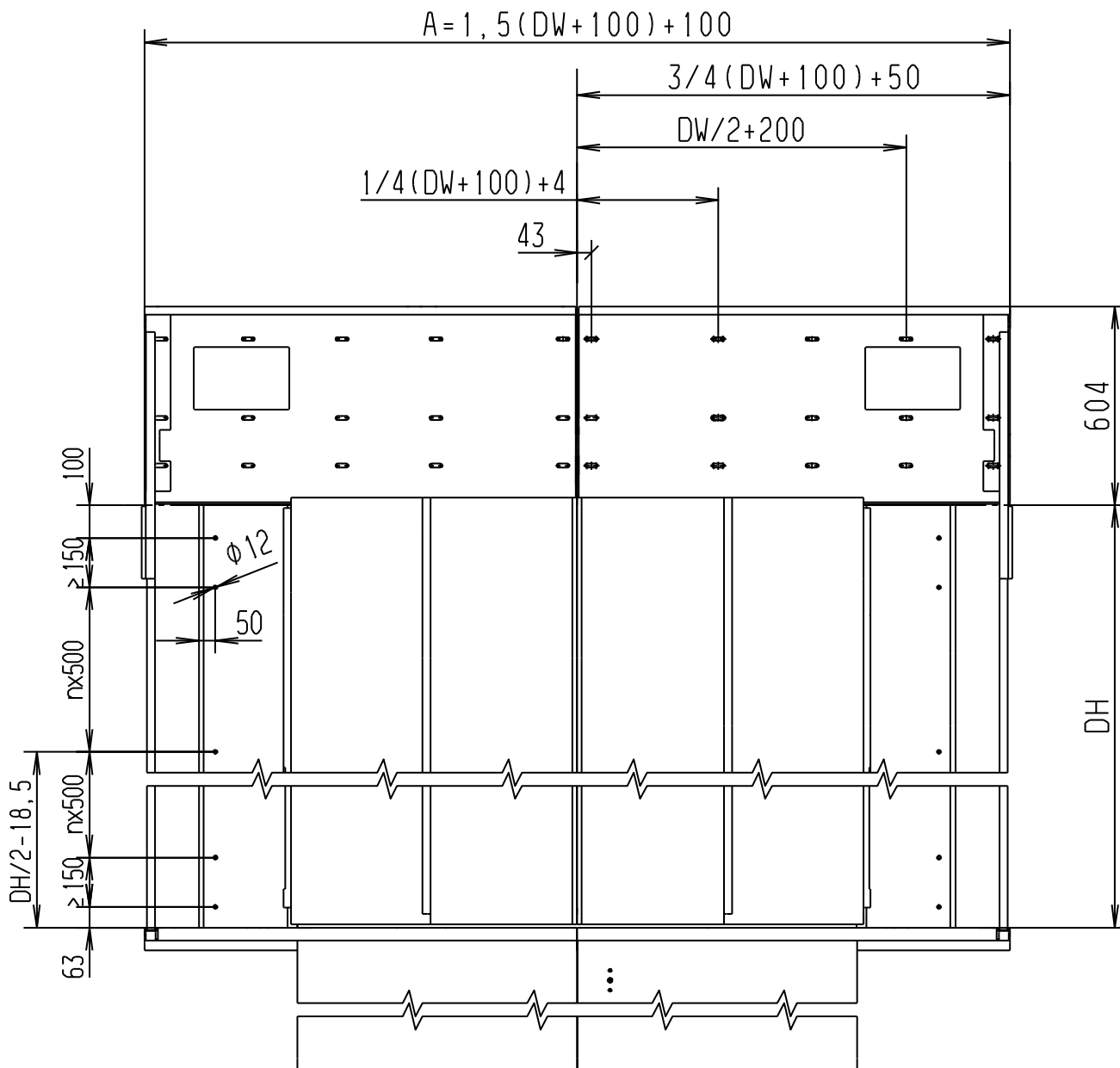

DW: Door width 1600 - 5300mm
 DH: Door height 2000 - 5000mm

Position of transom and sill fixing points C-4-C see figures at page 6-8

Subject to dimensional changes!

Sill fixing points C/L-4-C

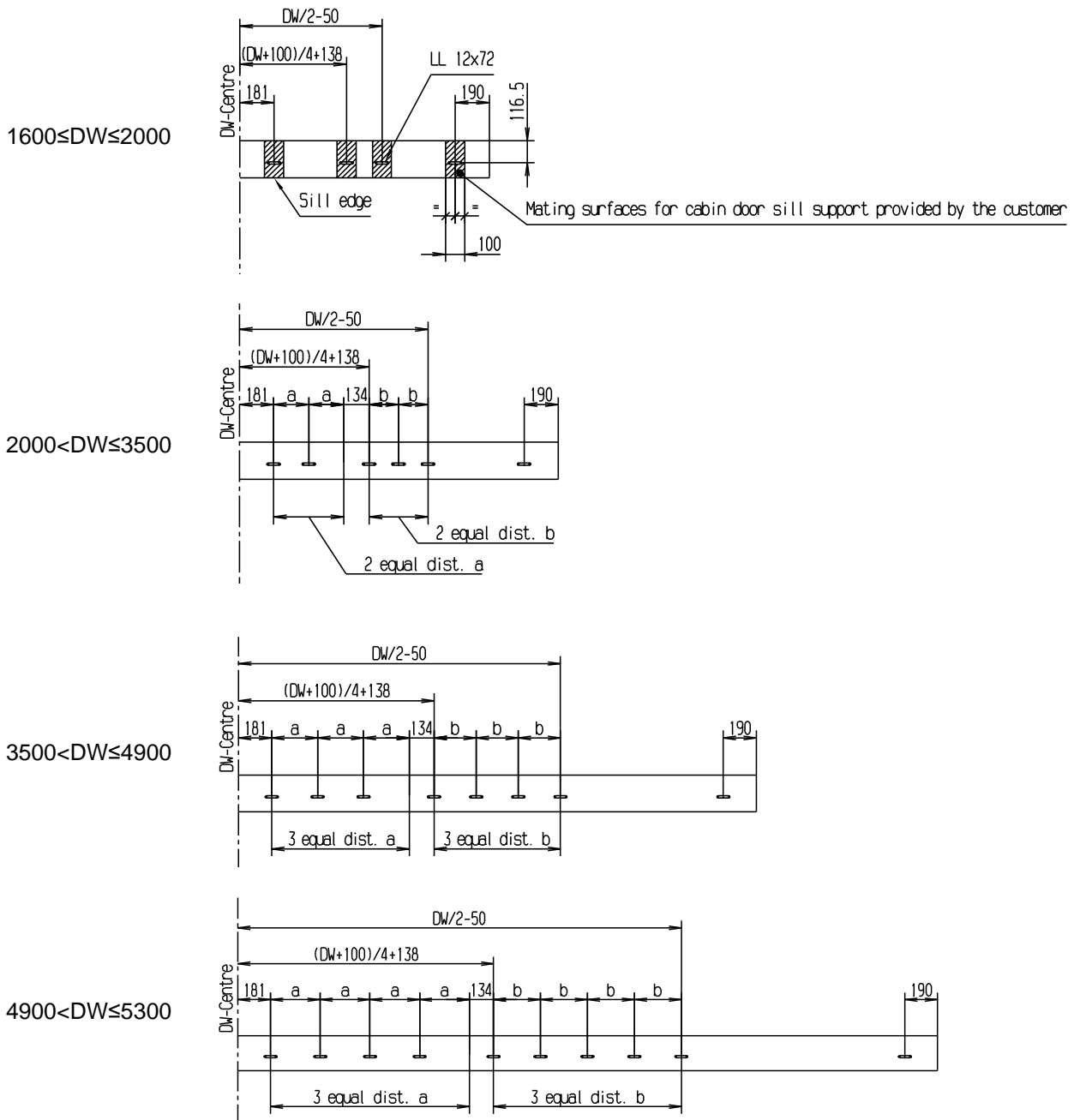

Hint: The position of the fixing points of the other half of the sill not shown can be figured out by mirroring at centre of DW!

Subject to dimensional changes!

Transom fixing points C/L-4-C

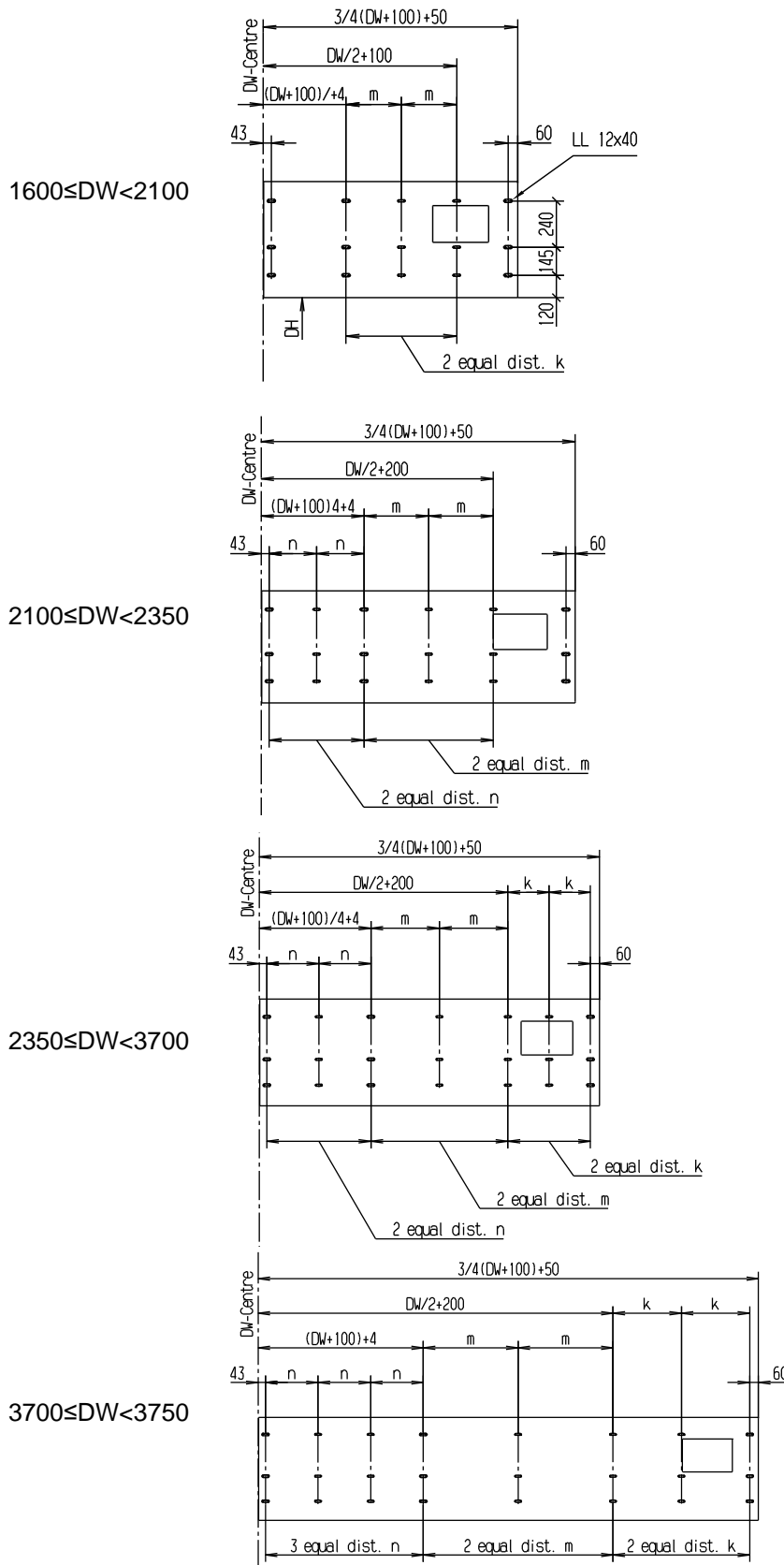

3750 ≤ DW < 4150

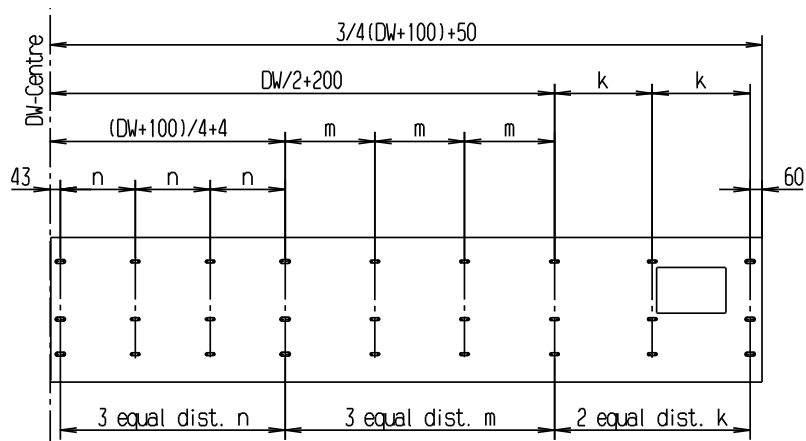

4150 ≤ DW ≤ 5300

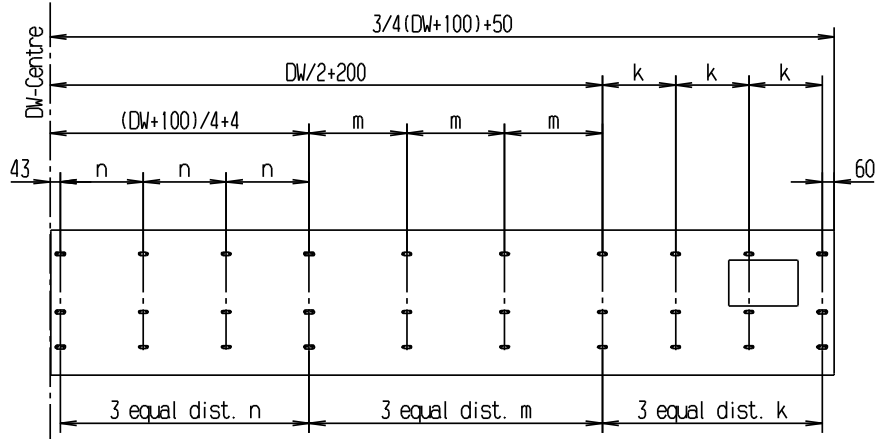

Hint: The position of the fixing points of the other half of the sill not shown can be figured out by mirroring at centre of DW!

Subject to dimensional changes!

Dimensioned sheet C-4-C

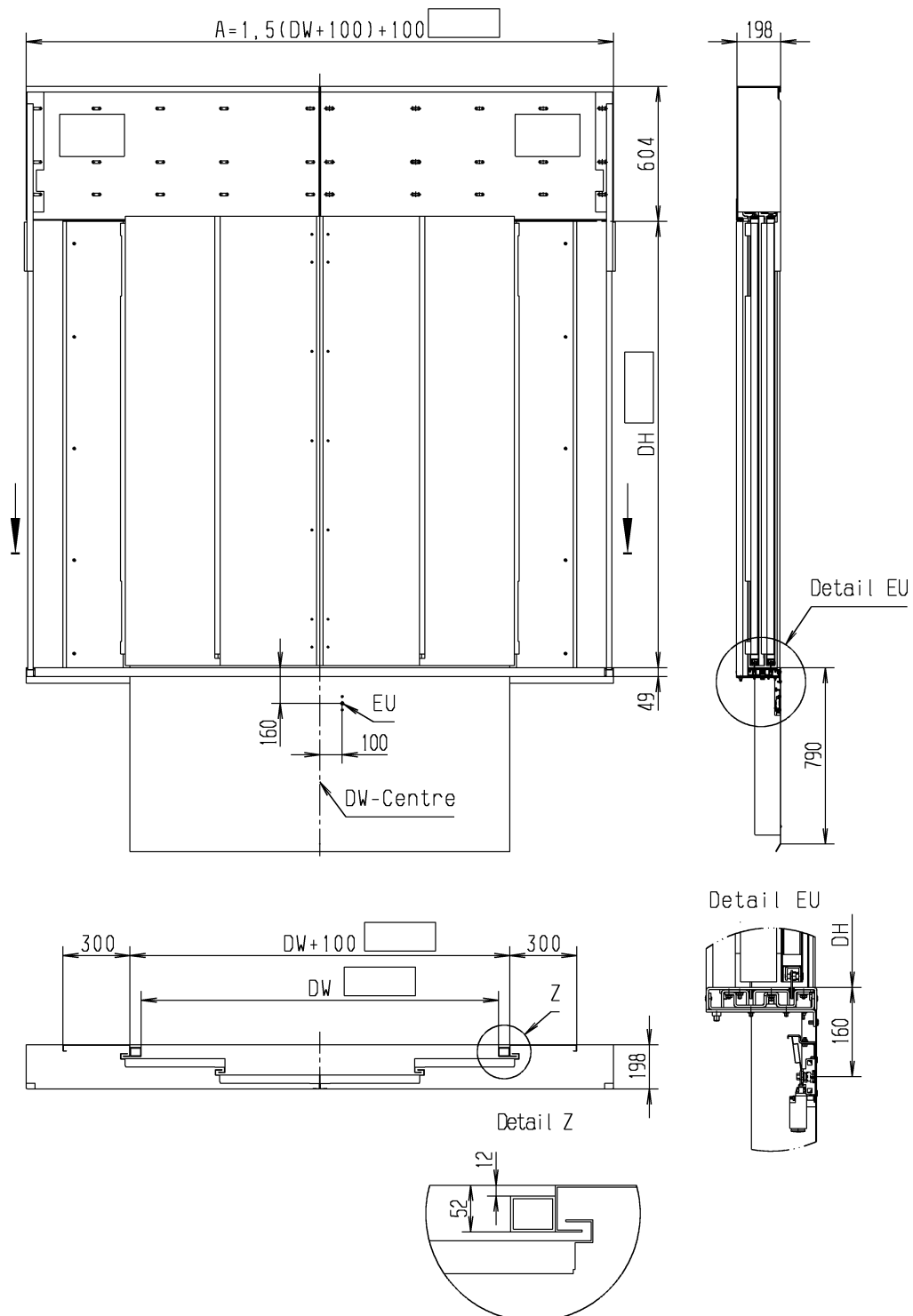

DW: Door width 2400 - 5300mm
DH: Door height 2000 - 5000mm

EU: Emergency unlocking

Subject to dimensional changes!

Fixing chart for centre-opening landing doors L-6-C

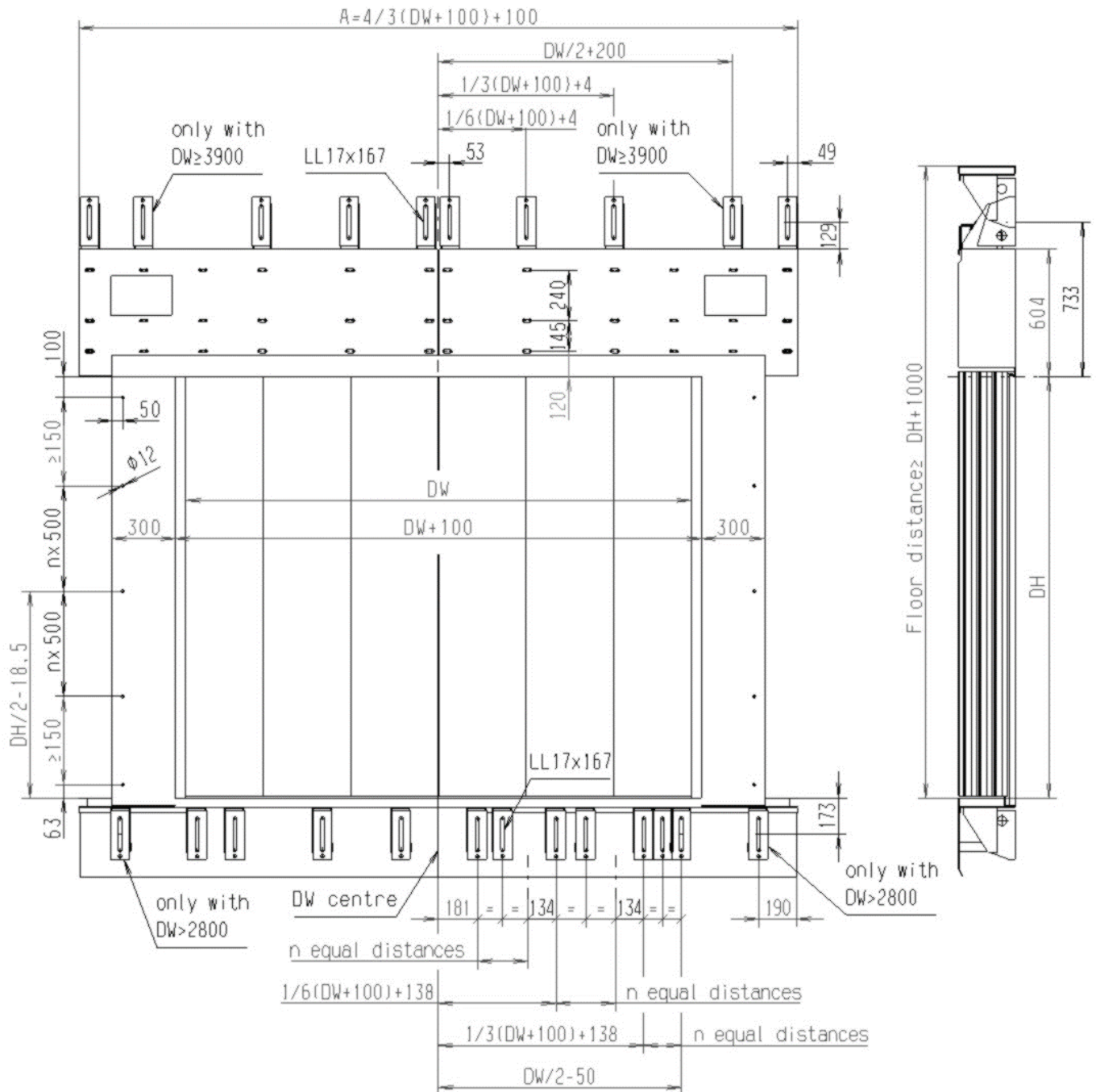

DW: Door width
DH: Door height

Position of transom fixing points L-6-C see figures at page 13-14

Subject to dimensional changes!

Dimensioned sheet L-6-C

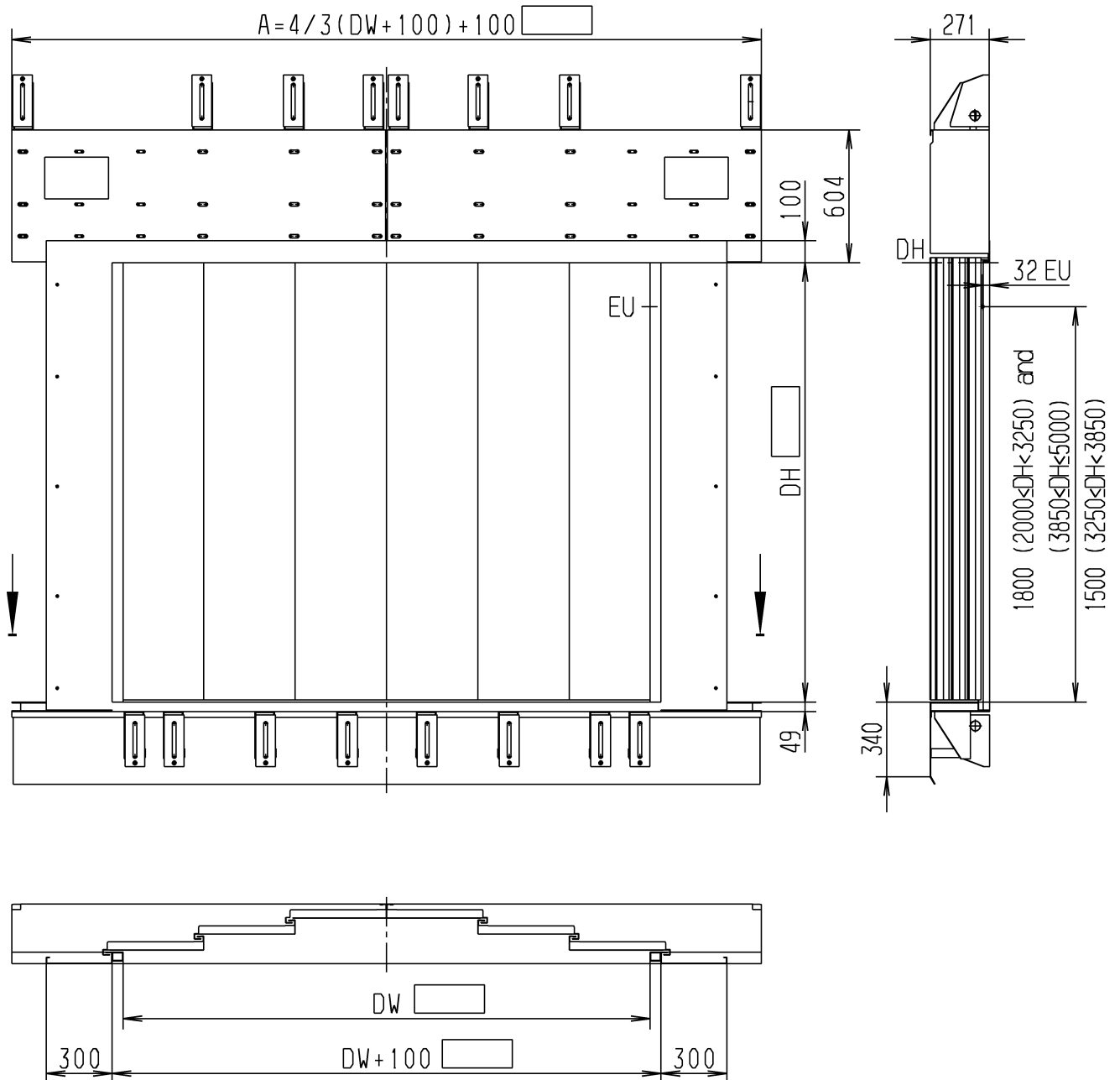

DW: Door width 2400 - 8000mm
 DH: Door height 2000 - 5000mm

EU: Emergency unlocking device (EU is fitted by default in the right side frame. It is possible to relocate the EU in the left side frame on site.)

Subject to dimensional changes!

Fixing chart for centre-opening car doors C-6-C

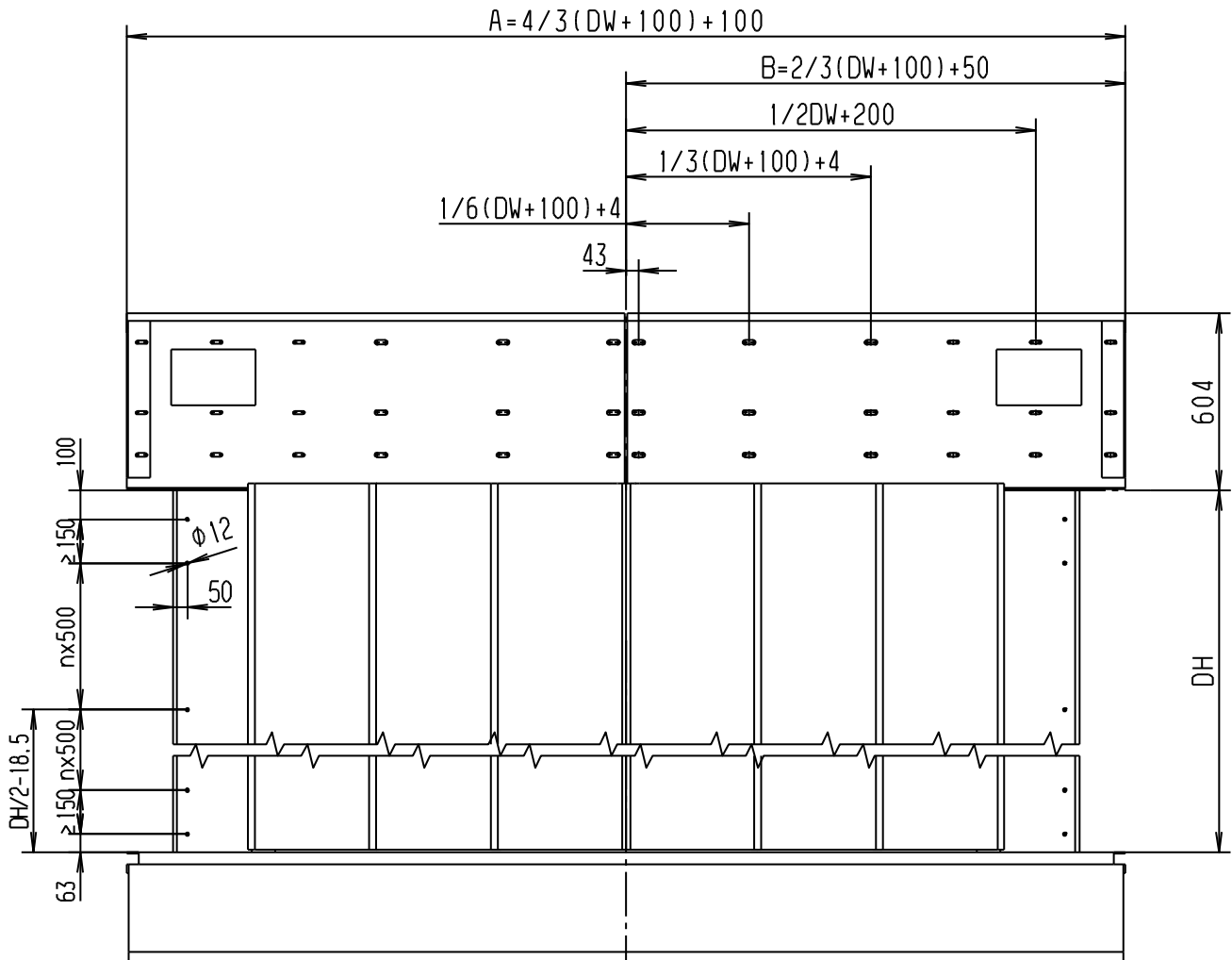

DW: Door width 2400 - 8000mm
 DH: Door height 2000 - 5000mm

Position of transom and sill fixing points C-6-C see figures at page 13-15

Subject to dimensional changes!

Sill fixing points C/L-6-C

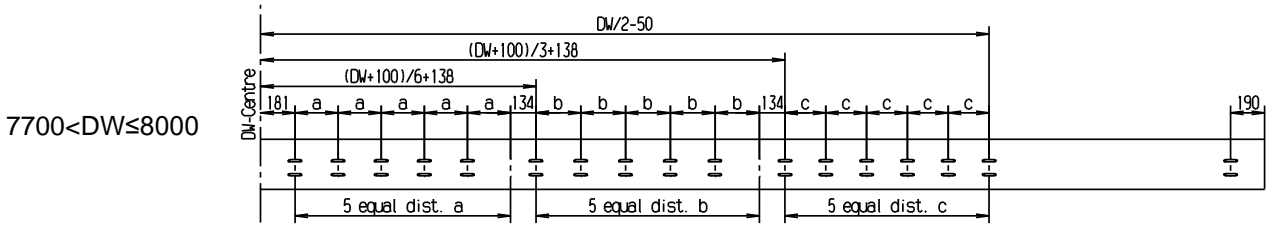
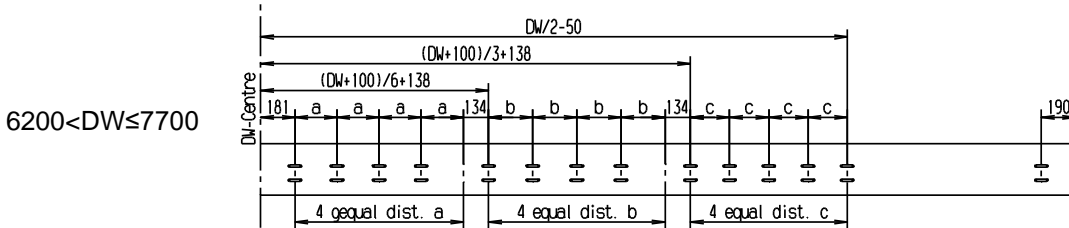
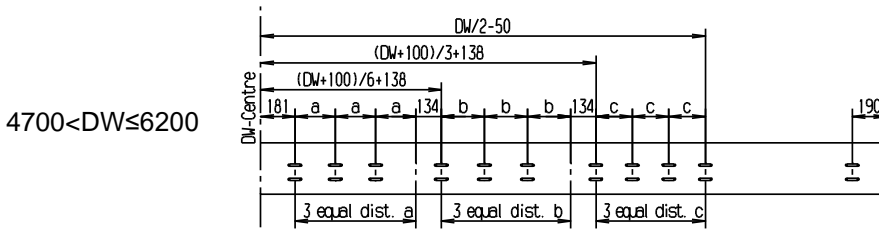
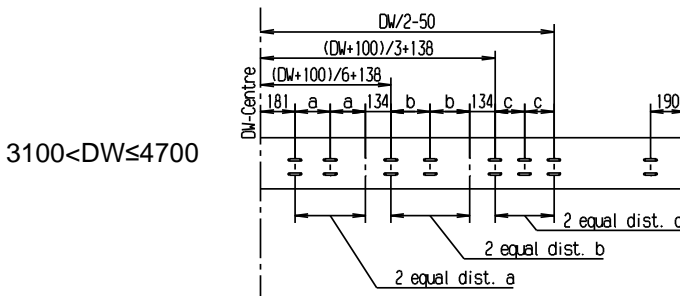
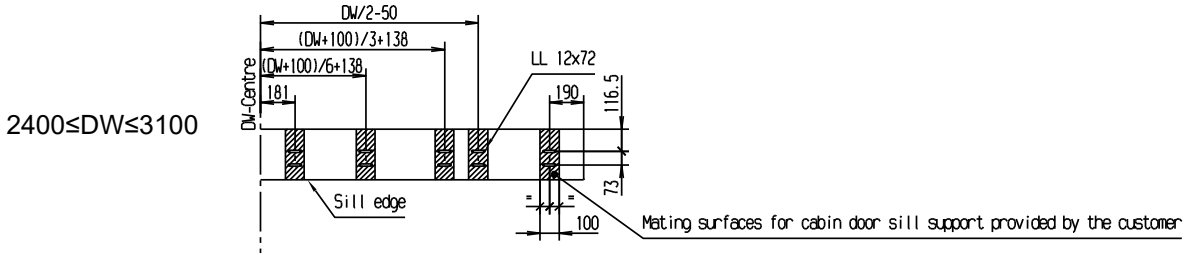

Hint: The position of the fixing points of the other half of the sill not shown can be figured out by mirroring at centre of DW!

Subject to dimensional changes!

Transom fixing points C/L-6-C

2400 ≤ DW < 2600

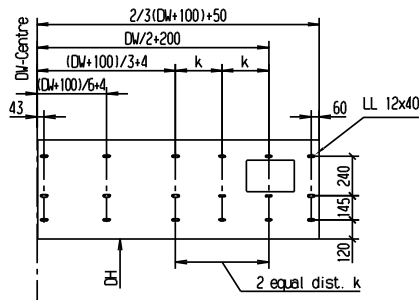

2600 ≤ DW < 3300

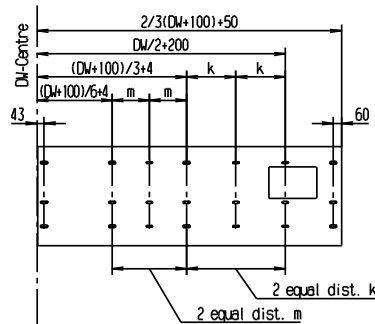

3300 ≤ DW < 3550

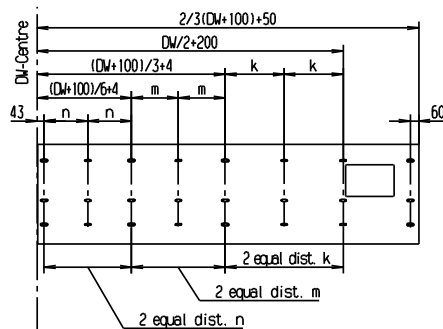

3550 ≤ DW < 4400

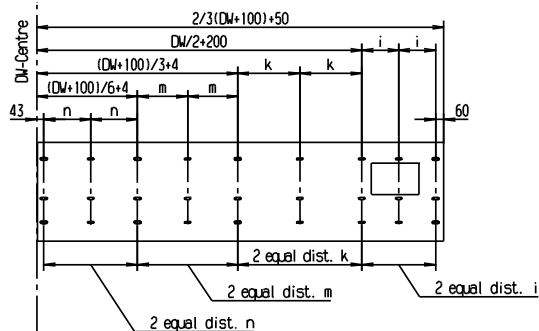

4400 ≤ DW < 5300

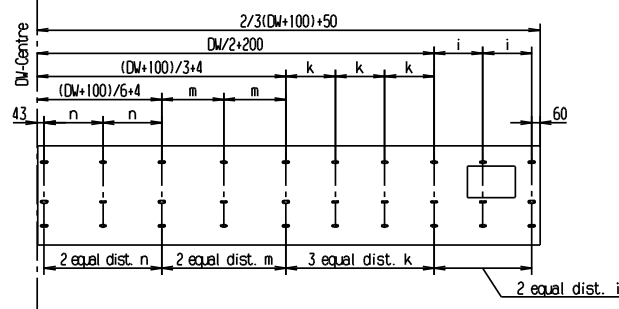

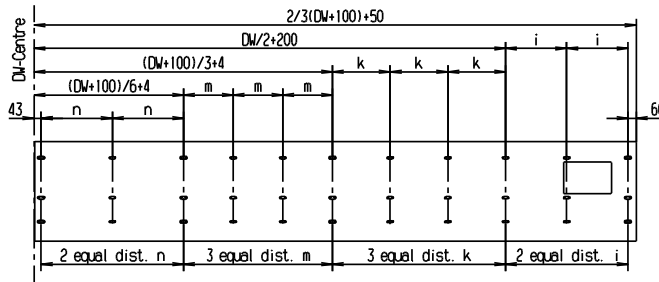
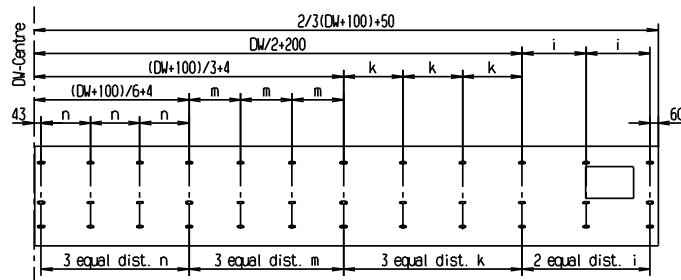
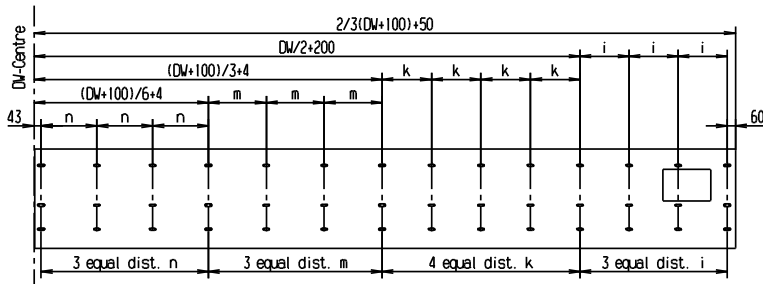
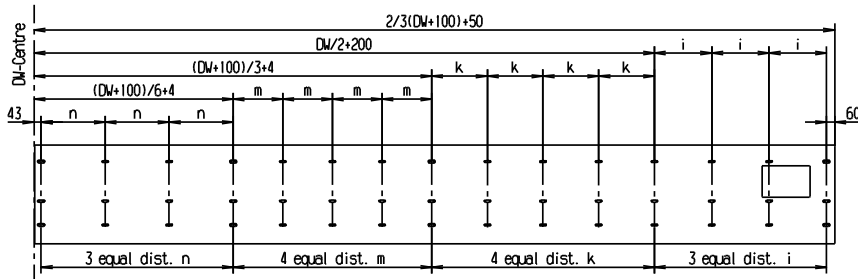
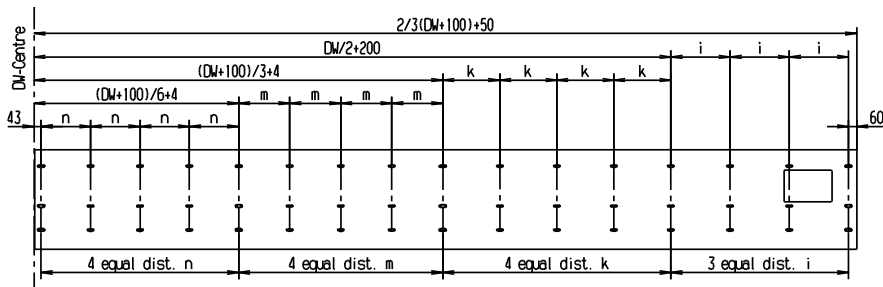
$5300 \leq DW < 5500$

 $5500 \leq DW < 6200$

 $6200 \leq DW < 7100$

 $7100 \leq DW < 7300$

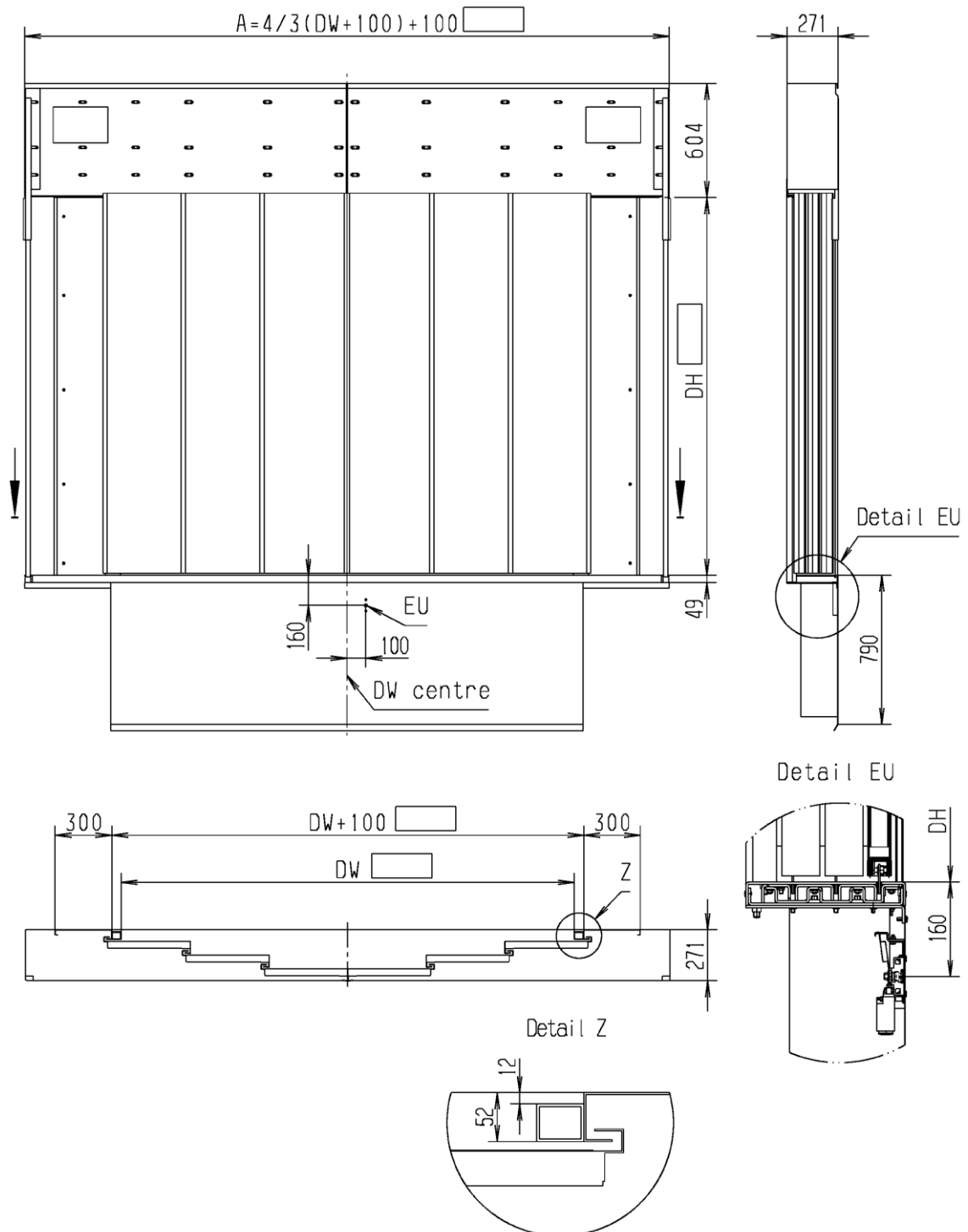
 $7300 \leq DW \leq 8000$

Hint: The position of the fixing points of the other half of the sill not shown can be figured out by mirroring at centre of DW!

Subject to dimensional changes!

Dimensioned sheet C-6-C



DW: Door width 2400 - 8000mm
DH: Door height 2000 - 5000mm

EU: Emergency unlocking

Subject to dimensional changes!

Fixing chart and number of toe-guard brackets C-6-C

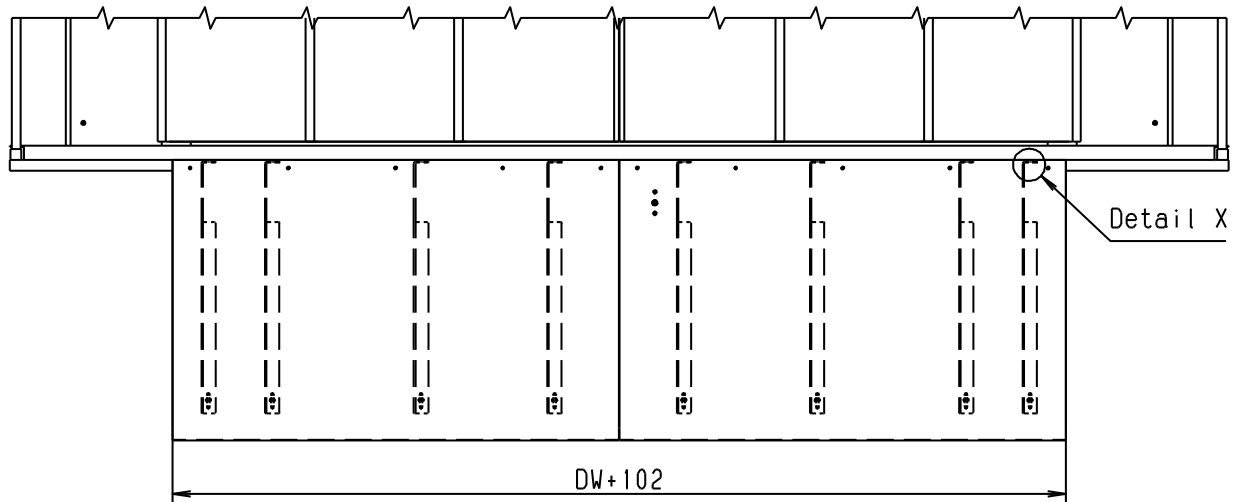

Zenit Xtreme C-4-C	
DW	Quantity
$1600 \leq DW \leq 2000$	6
$2000 < DW \leq 3500$	10
$3500 < DW \leq 4900$	14
$4900 < DW \leq 5300$	18

Zenit Xtreme C-6-C	
DW	Quantity
$2400 \leq DW \leq 3100$	8
$3100 < DW \leq 4700$	14
$4700 < DW \leq 6200$	20
$6200 < DW \leq 7700$	26
$7700 < DW \leq 8000$	32

Detail X

Material thickness of fixing brackets
provided by customer $t \leq 10\text{mm}$

